

**HYUNDAI**  
POWER PRODUCTS

## **GASOLINE GENERATOR SET**

**HG2800(E)**

**HG3000(E)**

**HG5500(E)**

**HG6000(E)**

**HG7500(E)**

**HG8500(E)**

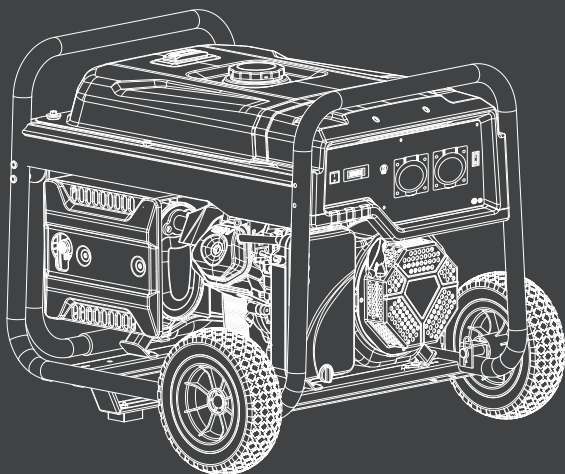



Thank you for choosing a generator set of our company.

This manual contains the information on how to do that. Please read it carefully before operating. Operating safely and correctly can help you get the best results.

All information in this publication is based on the latest product information available at the time of printing. The contents in this manual may be different from the actual parts due to revision and other changes.

Our company reserves the right to make changes at any time without notice and without incurring any obligation. No part of this publication may be reproduced without our company's written permission.

This manual should be considered a permanent part of the generator and should accompany the generator if it is resold.

---

## SAFETY MESSAGES

Your safety and the safety of others are very important. We have provided important safety messages in this manual and on the generator. Please read these messages carefully.

A safety message alerts you to potential hazards that could hurt you or others. Each safety message is preceded by a safety alert symbol  and one of three words: DANGER, WARNING, or CAUTION. Meaning as follows:

### DANGER

You **WILL** be **KILLED** or **SERIOUSLY HURT** if you don't follow instructions.

### WARNING

You **CAN** be **KILLED** or **SERIOUSLY HURT** if you don't follow instructions.

### CAUTION

You **CAN** be **HURT** if you don't follow instructions.

### NOTICE

Your generator or other property could be damaged if you don't follow instructions.

---

# CONTENTS

SAFETY MESSAGES .....	2
CONTENTS .....	3
1. SAFETY NOTICE.....	5
1. Safety Standard .....	5
2. Special Requirements.....	6
2. COMPONENT IDENTIFICATION .....	8
1. Structure Feature .....	8
2. Engine Type & Serial Number .....	12
3. CONTROL.....	11
1. Generator Switch .....	11
2. Recoil Starter .....	11
3. Fuel Valve .....	12
4. Choke Lever .....	12
5. AC Circuit Breaker .....	13
6. Ground Terminal .....	13
7. Oil Alert System.....	13
4. GENERATOR OPERATION.....	14
1. Connection to the Household Power Supply .....	14
2. Generator Grounding .....	15
3. AC Current .....	15
4. DC Current.....	16
5. PRE-OPERATION CHECK .....	18
1. Engine Oil .....	18
2. Fuel .....	19

3. Battery .....	20
6. STARTING THE ENGINE .....	21
1. Recoil Starter .....	21
2. Electric starting .....	21
7. STOPPING THE ENGINE .....	22
8. MAINTENANCE .....	23
1. Engine Oil Change .....	24
2. Air Cleaner Service .....	25
3. Fuel Sediment Cup Cleaning .....	26
4. Spark Plug Service .....	27
9. STORAGE .....	28
10. TROUBLESHOOTING .....	30
11. WIRING DIAGRAM .....	31
12. SPECIFICATIONS .....	34
13. WHEEL (OPTION) .....	36

# 1. SAFETY NOTICE

## 1. Safety Standard

Read and understand this owner's manual before operating your generator. You can help prevent accidents by being familiar with your generator's controls, and by observing safe operating procedures.

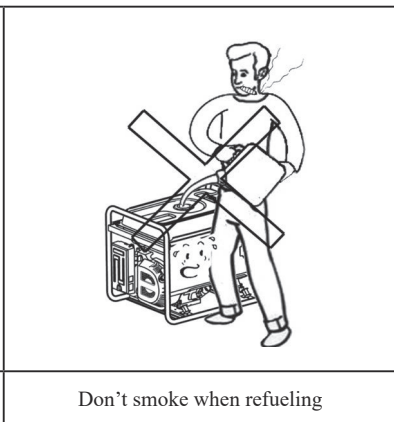
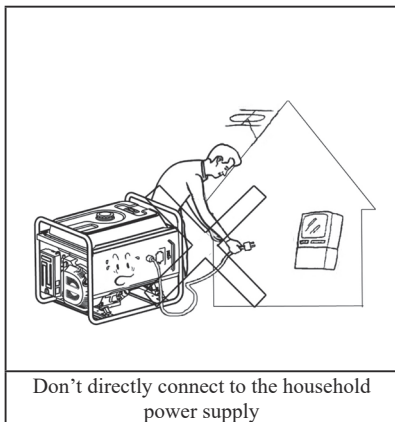
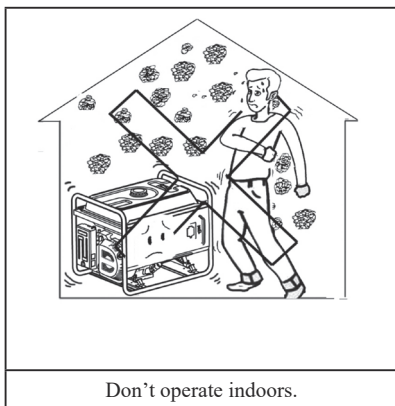

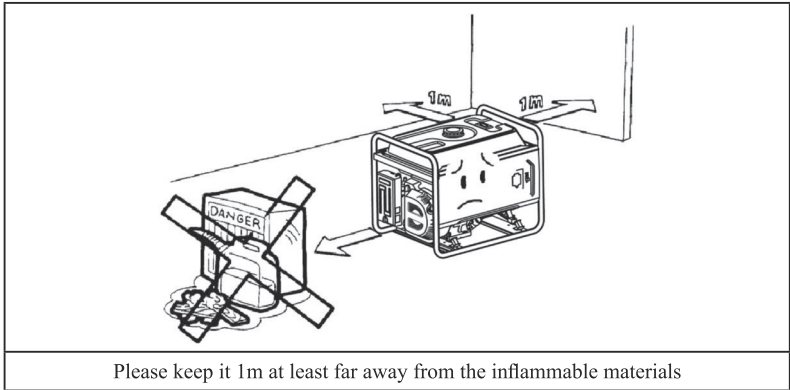
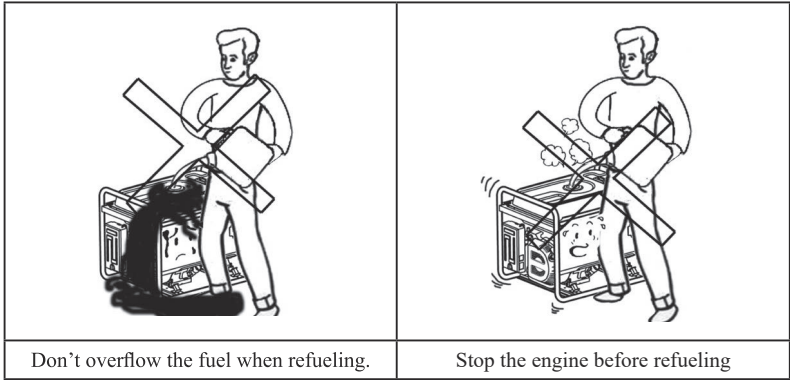

## 2. Special Requirements

- Electrical equipment, including lines and plug connections should be free from being bare.
- The circuit breakers should match with the generator equipment. If the circuit breakers require replacement, they must be replaced with a circuit breaker of the same ratings and performance characteristics.
- Don't operate the generator before grounding.



- If using extension lines, the requirement should be met as following:  
for  $1.5\text{mm}^2$ , the line should not be exceeded 60m; for  $2.5\text{mm}^2$ , the  
line not exceeded 100m.

 **WARNING**

Do not switch between 110v and 220v while under a load.

Do not switch between 115v and 230v while under a load.

## 2. COMPONENT IDENTIFICATION

### 1. Structure Feature

Recoil Starter

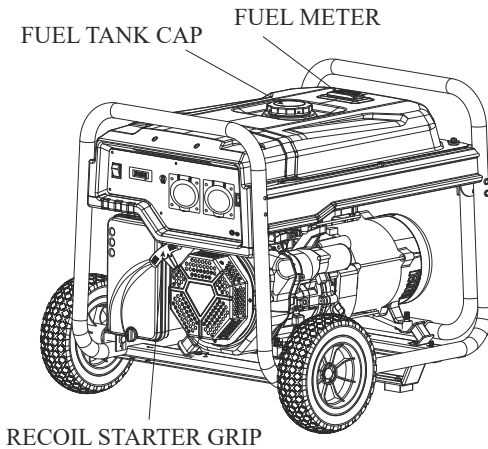
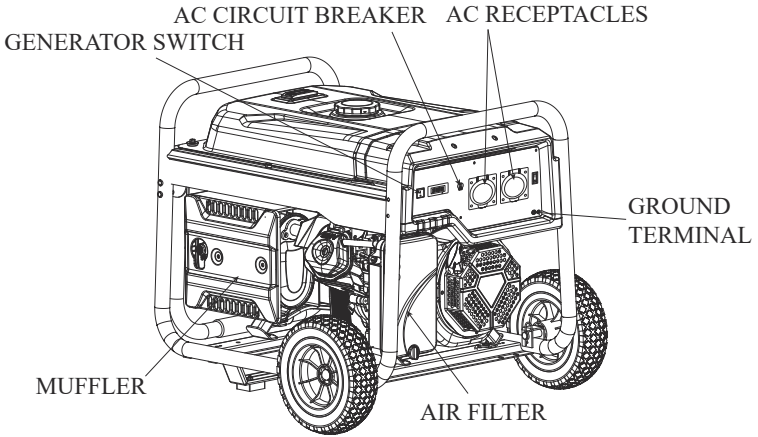

Recoil/Electric Starter

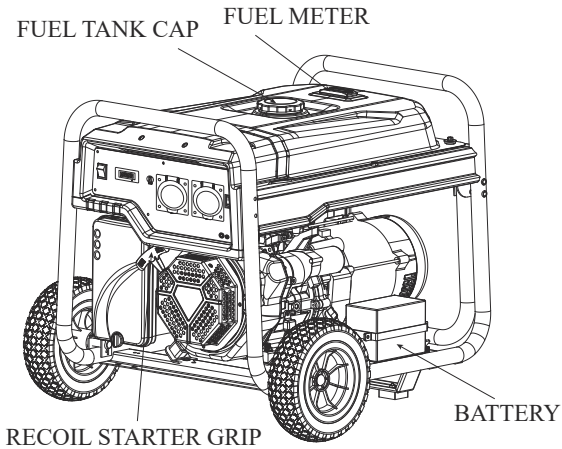
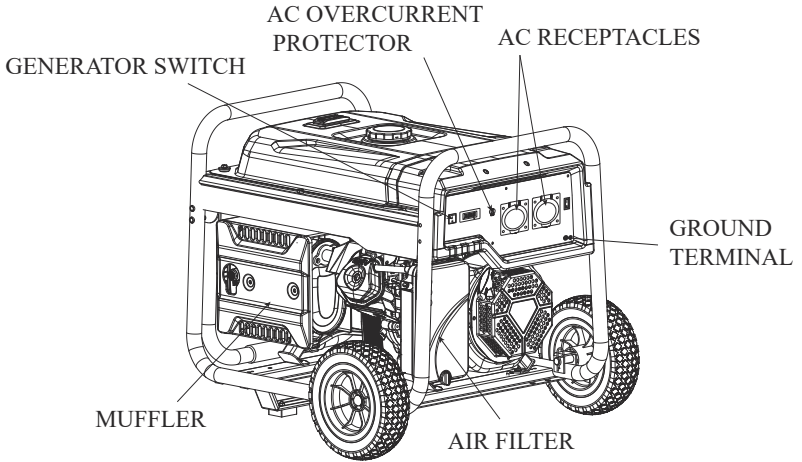

## Recoil Starter(3 Phase)

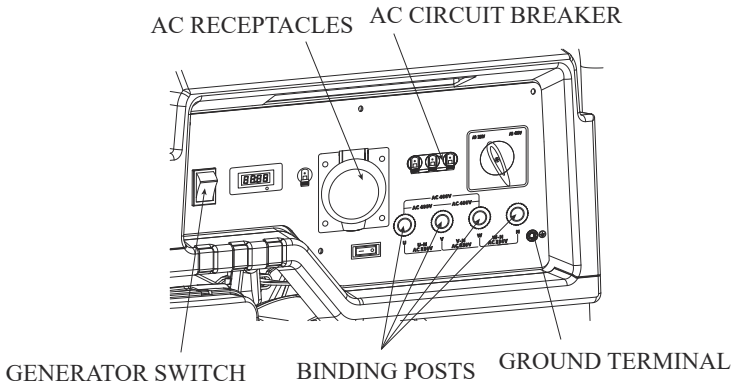

## 2. Engine Type & Serial Number

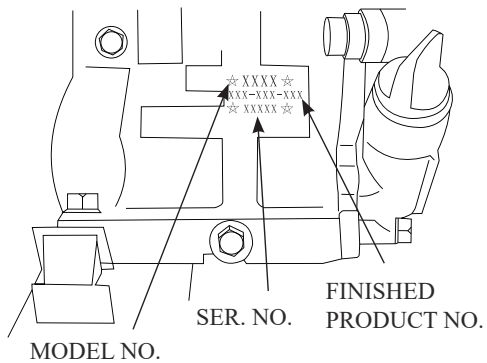

### 3. CONTROL

#### 1. Generator Switch

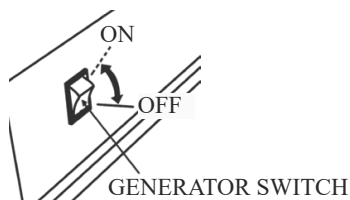

Recoil Starter

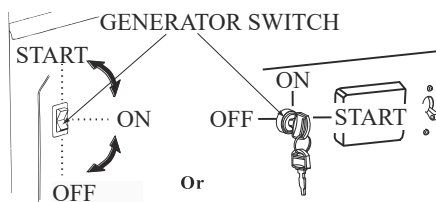

Recoil/Electric Starter

#### 2. Recoil Starter

To start the engine, pull the starter grip lightly until resistance is felt, then pull briskly.

#### NOTICE

**Do not allow the starter grip to snap back against the engine.**

**Return it gently to prevent damage to the starter.**

STARTER GRIP

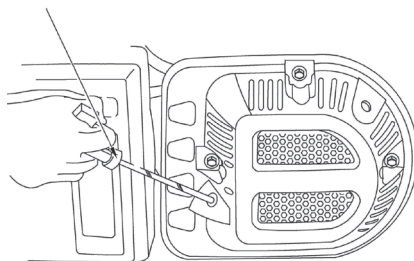

### 3. Fuel Valve

The fuel valve controls fuel flowing from the fuel tank to carburetor. Be sure to return the lever to “OFF” after stopping the engine.

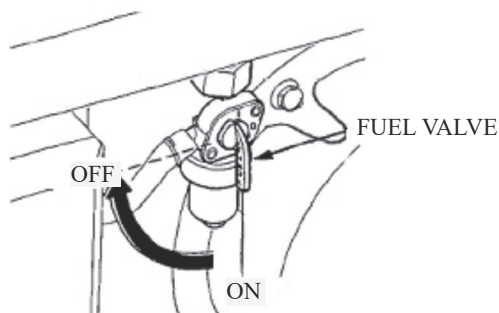

### 4. Choke Lever

The choke lever is used to provide an enriched fuel mixture when starting a cold engine. Slowly put the choke lever to “OPEN” position after the engine is started.

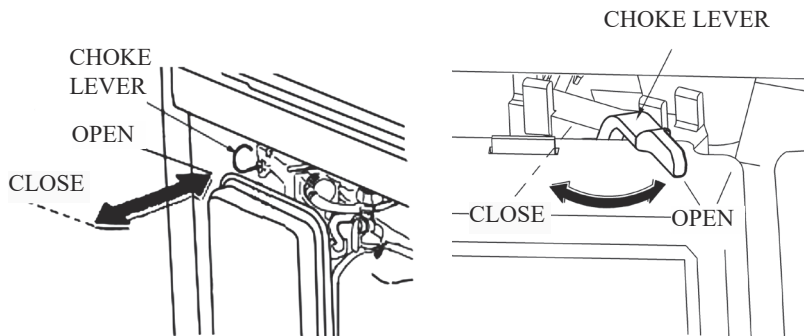

## 5. AC Circuit Breaker/Overcurrent Protector

The overload current will automatically switch off circuit breaker to avoid short circuiting of the load or overload. If the indicator of AC Overcurrent Protector is raised, the Overcurrent Protector is now in the “OFF” position. Press the button of AC Overcurrent Protector to the “ON” position again a few minute later. If the circuit breaker is switched OFF automatically, switch the circuit breaker ON again.

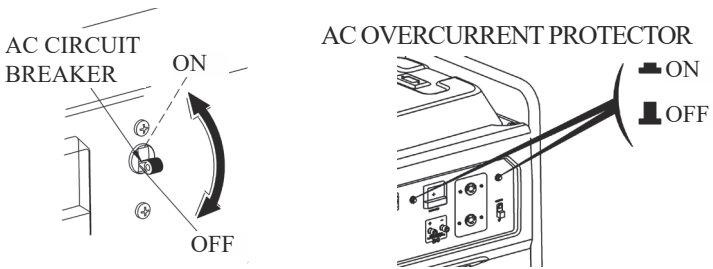

## 6. Ground Terminal

This ground terminal is dedicated to reliably grounding the whole generator.

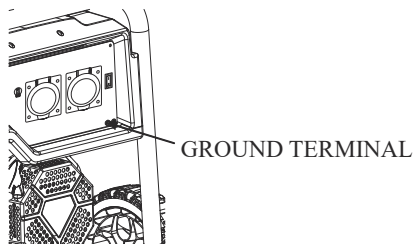

## 7. Oil Alert System

The oil alert system is especially designed to prevent engine damage caused by an insufficient amount of oil in the crankcase. When the oil level in the crankcase fall down below the safe limit, the oil alert system will automatically shut down the engine(though the generator switch still remain in the ON position), so that the engine can't be damaged due to the insufficient amount of the oil.

## 4. GENERATOR OPERATION

Generator operation environment:

- Temperature:-15℃ ~40℃
- Humidity: below 95%.
- Height above sea level: below 1,000m(If the area is over 1,000m high, the power should be lowered for operation).

### 1. Connection to the Household Power Supply

#### NOTICE

When connecting the generator to a household power supply, connection must be made by a qualified electrician. After connecting, carefully check electric connection for their safety and reliability, if not, damage to the generator, burning and firing may be caused.

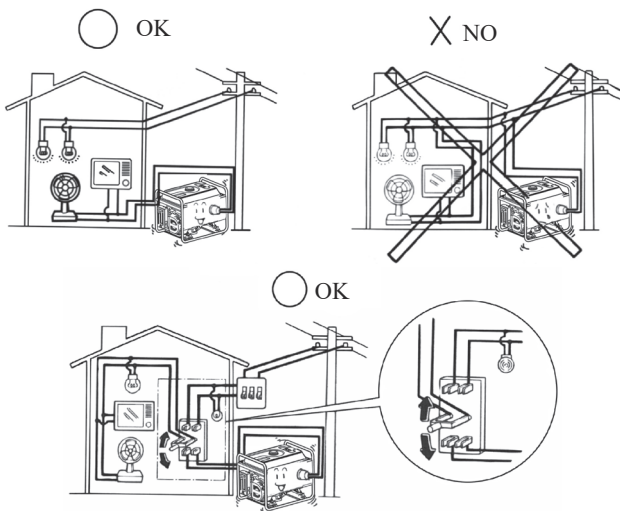



## 2. Generator Grounding

To prevent electrical shock or misuse from faulty appliances, the generator should be grounded with an insulated lead.

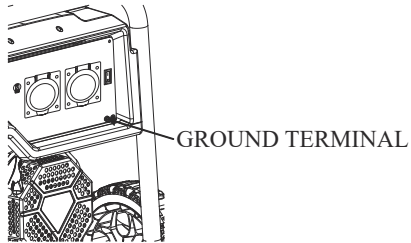

## 3. AC Current

Before starting the generator, make sure that total power of loads (total of resistive, capacitive and inductive loads) does not exceed rated power of the generator.







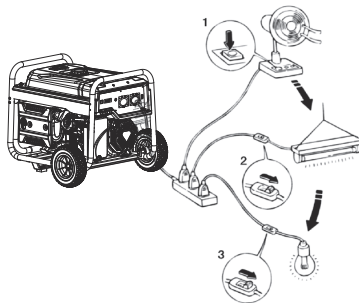

### NOTICE

**Overload operation will greatly shorten generator service life.**

If the generator set is connected to multiple loads or electric appliances, please first connect to one with the highest starting power, then, the one with the second highest starting power, and connect others one by one, each with a lower starting power than the preceding one, finally, connect the one with the lowest starting power.



In general, capacitive and inductive loads, especially, motor-driven devices have a big starting current when starting. The following table is a reference for when connecting to the electric appliances

Type	Wattage		Typical Device	Examples		
	Start	Rated		Device	Starting	Rated
Incandescent Lamp Heating Device	×1	×1	 Incandescent Lamp  Tv Set	 Incandescent Lamp 100W	100VA (W)	100VA (W)
Fluorescent Lamp	×2	×1.5	 Fluorescent Lamp	 Fluorescent Lamp 40W	80VA (W)	60VA (W)
Motor Drive Device	×3-5	×2	 Refrigerator  Electric Fan	 Refrigerator 150W	450-750VA (W)	300VA (W)

## 4. DC Current

### DC Terminals

The DC terminals are used to provide power supply for lower-power DC loads and charging other batteries.

The terminals are colored as such:red to identify the positive (+) terminal and black to identify the negative (-) terminal. Load connection method: The load must be connected to DC terminals with the proper polarity (load's positive to positive of DC terminal and load's negative to negative of DC terminal).

## DC OVERCURRENT PROTECTOR

The overload current will automatically switch off overcurrent protector to avoid short circuit of the load or overload. If the indicator of overcurrent protector is raised, the overcurrent protector is now in the “OFF” position. Press the button of overcurrent protector to the “ON” position again.

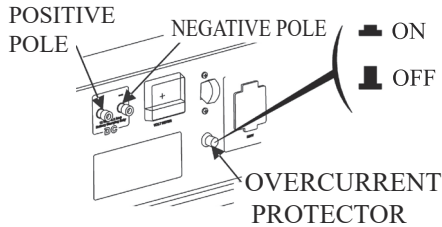

## 5. PRE-OPERATION CHECK

### 1. Engine Oil

#### NOTICE

**Engine oil is a major factor affecting engine performance and service life. Non-detergent and 2-stroke engine oils will damage the engine and are not recommended. Check the oil level before each use with the generator on a level surface with the engine stopped.**

Recommended engine oil  
4-stroke gasoline engine oil  
SF under API service classification  
or SAE10W-30(equivalent to SG class).

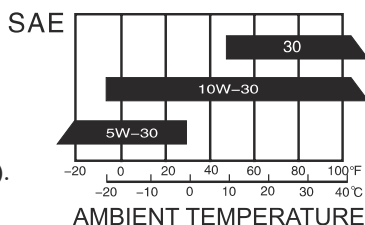

Method of checking engine oil level:

Remove the oil filler cap and wipe the dipstick to clean it.

Check the oil level by inserting the dipstick into the filler neck without screwing it in.

If the level is low, add the recommended engine oil until level can reach the upper mark on the dipstick.

After adding, don't forget to refit and screw the oil dipstick tight.

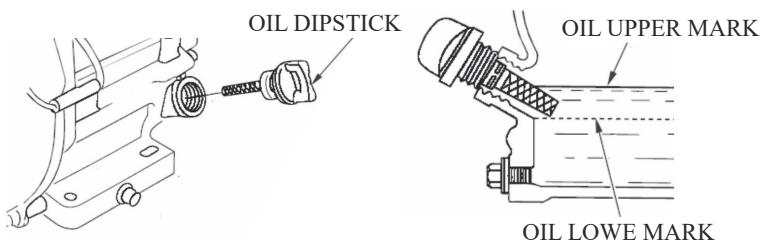

## 2. Fuel

- 1) Check the fuel level gauge,
- 2) Replenish the tank if the fuel level is low. Do not let oil level rise above the shoulder of the fuel strainer.
- 3) Refit and screw the fuel tank cap tight after refueling.

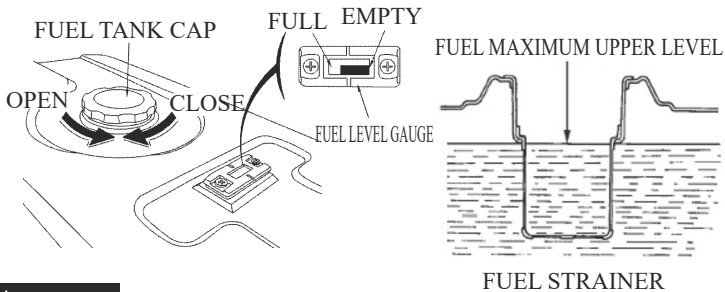

### **⚠ WARNING**

- **Refuel in a well-ventilated area with the engine stopped. Never smoke or allow flames or sparks in the area where the engine is refueled or where gasoline is stored.**
- **Do not overfill the fuel tank.**
- **Avoid repeated or prolonged contact with skin or breathing in of fuel vapor.**
- **Keep children from contacting fuel.**
- **Never use the oil/gasoline mixture or gasoline contained impurity.**

Use gasoline with octane rating  $\geq 90$  .

We recommend unleaded gasoline because it produces fewer engine carbon deposits and spark plug deposits and extends exhaust system's life.

Never use stale or contaminated gasoline or oil/gasoline mixture. Avoid getting dirt or water into the fuel tank.

### 3. Battery

#### **NOTICE**

**Don't connect the battery positive and negative poles reversely (pay attention to leads mark), if not, serious damage may be caused to the generator set and battery.**

#### **⚠ WARNING**

- **If improper operation, the battery may be explosive and may potentially hurt persons nearby. Keep the fire and inflammable materials far away from the battery .**
- **The battery will release the explosive gas, please keep the fire far away from it. Keep a good air ventilation condition when battery is being charged or used.**

## 6. STARTING THE ENGINE

### 1. Recoil Starter

- (1) Remove all the loads from the output side.
- (2) Turn the fuel valve to the “ON” position.
- (3) Turn the AC circuit breaker to the “OFF” position.
- (4) Turn the choke lever to the “CLOSE” position.

#### NOTICE

**Don't close the choke when starting the engine in warm state**

- (5) Turn the generator switch to the “ON” position.
- (6) Pull the starter grip until a resistance is felt, then pull it out briskly.
- (7) Turn the choke lever to the “OPEN” position after the engine is warm.
- (8) Don't use electric apparatus before setting circuit breaker to the “ON” position.

### 2. Electric starting

- (1) Remove all the loads from the output side .
- (2) Turn the fuel valve to the “ON” position.
- (3) Turn the choke lever to the “CLOSE” position.

#### NOTICE

**Don't close the choke when starting the engine in warm state.**

- (4) Turn the generator switch to electric starting position.
- (5) After starting engine, immediately release generator switch and generator switch can automatically return to open position.

- (6) Turn the choke lever to “OPEN” position after the engine is warm.

**NOTICE**

Turn the GENERATOR switch to electric position and hold for more than 5 seconds or damage may be caused to the starting motor. If starting fails, release the switch and wait for 10 seconds before operating it again.

If the speed of the starting motor drops fast after a period of time, it suggests the battery should be recharged.

## **7. STOPPING THE ENGINE**

- (1) Turn the AC circuit breaker to the OFF position.
- (2) Turn the generator switch to the OFF position.
- (3) Turn the fuel valve to the OFF position.

**NOTICE**

To stop the engine in an emergency, turn the generator switch to the OFF position.



## 8. MAINTENANCE

The engine must be properly maintained to ensure its operation be safe, economy and trouble-free, as well as eco-friendly.

In order to keep your gasoline engine in good working condition, it must be periodically serviced. The following maintenance schedule and routine inspection procedures must be carefully followed

Items		Frequency	Each time	First 1 month or first 20hrs of operation	Thereafter, every 3 months or every 50hrs of operation	Every year or every 100 hrs of operation
Engine oil	Check- Refill		√			
	Replace			√	√	
Reduction gear oil(if equipped)	Oil level check		√			
	Replace			√	√	
Air filter element	Check		√			
	Clean			√		
	Replace				√	
Deposit Cup( if equipped)	Clean					√
Spark Plug	Check - adjust					√*
Spark arrester	Clean				√	
Idling ( if equipped)**	Check - adjust					√
Valve clearance **	Check-adjust					√
Fuel tank & fuel filter **	Clean					√
Fuel line	Check	Every 2 years( change if necessary)				
Cylinder head, piston	Clean up carbon **	< 225cc, Every 125hrs ≥225cc, Every 250hrs				

\* These items should be replaced if replacement needed.  
 \*\* These items should be maintained and repaired by our authorized dealer, unless the owner has appropriate tools and is proficient with mechanical maintenance.

### NOTICE

- If the gasoline engine frequently work under high temperature or heavy load, change the oil every 25 hours.
- If the engine frequently work under dusty or other severe circumstances, clean the air filter element every 10 hours; If necessary, change the air filter element every 25 hours.

- The maintenance period and the exact time (hour), the one which comes first should govern.
- If you have missed the scheduled time to maintain your engine, do it as soon as possible.

**⚠ WARNING**

**Stop the engine before servicing. Put the engine on a level surface and remove the spark plug cap to prevent the engine from starting. Never run your engine in a poorly ventilated room or other enclosed area, be sure to keep good ventilation in working area. The exhaust from the engine may contain poisonous CO, inhalation can cause shock, unconsciousness and even death.**

## 1. Engine Oil Change

Drain the oil while the engine is warm to ensure complete and rapid draining.

1. Remove the oil dipstick and drain plug to drain the oil.
2. Reinstall the drain plug, then tighten the plug securely.
3. Refill oil and check the oil level.

Oil capacity: 2.2kW 0.55L  
5.5kW/6.5kW 1.1L  
8.5kW 1.2L

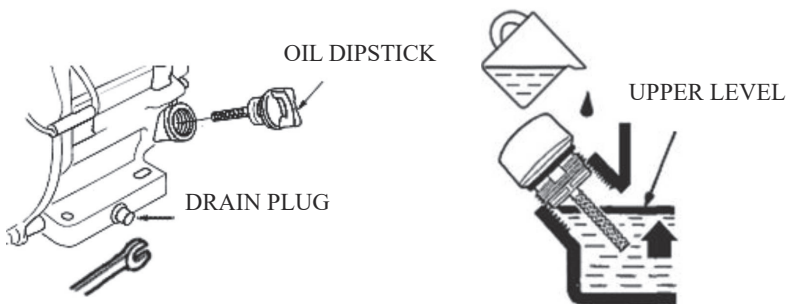

**⚠ CAUTION**

**Used engine oil may cause skin cancer if repeatedly left in contact with the skin for prolonged periods. Although this is unlikely unless you handle used oil on a daily basis, it is still advisable to thoroughly wash your hands with soap and water as soon as possible after handling used oil.**

Please dispose of used engine oil in a manner that is compatible with the environment. We suggest you take use a sealed container to take it to your local service station or recycling center for reclamation. Do not throw it in the trash or pour it on the ground.

## 2. Air Cleaner Service

A dirty air cleaner will restrict air flow into the carburetor. To prevent carburetor malfunction, service the air cleaner regularly. Service more frequently when operating the generator in extremely dusty areas.

**⚠ CAUTION**

**Using gasoline or flammable solvent to clean the filter element can cause a fire or explosion. Use only soapy water or a nonflammable solvent.**

**NOTICE**

Never run the generator without the air cleaner. If not, rapid engine wear will result.

- (1) Open the air cleaner clip and open the air cover. Check the air cleaner element to see if it's complete and clean.
- (2) If the air cleaner element is dirt, please clean it: Wash the air cleaner

element in a solution of household detergent and warm water, then rinse thoroughly or wash in nonflammable or high flash point solvent: Drop a few points engine oil in, then, squeeze out.

AIR CLEANER COVER

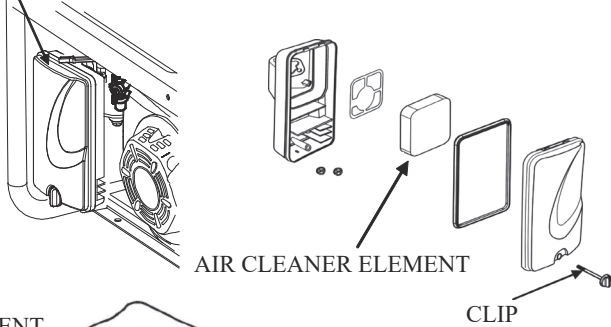

ELEMENT

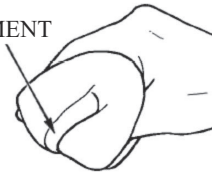

(3) Reinstall the air cleaner element and the cover.

### 3. Fuel Sediment Cup Cleaning

(1) Turn the fuel valve to the OFF position. Remove the sediment cup, o-ring and strainer according to the arrow direction.

(2) Clean the sediment cup, and o-ring,

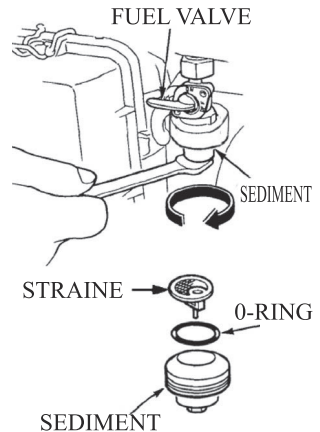

and strainer in nonflammable or high flash point solvent.

- (3) Reinstall the o-ring, and strainer and screw back the sediment cup.
- (4) Turn the fuel valve ON and check for leaks.

#### 4. Spark Plug Service

Recommended spark plugs: F7RTC  
or other equivalents

- (1) Remove the spark plug cap.
- (2) Use the plug wrench to remove the spark plug.
- (3) Visually inspect the spark plug to see if the insulator is cracked, if so, replace it with a new the spark plug.
- (4) Measure the plug gap with a feeler gauge. Correct as necessary by carefully bending the side electrode. The gap should be: 0.70-0.80 mm.
- (5) Check the spark plug washer to see if it's good.
- (6) Reinstall the spark plug, tighten it with the plug wrench and impact the washer. Reinstall the spark plug cap accurately.

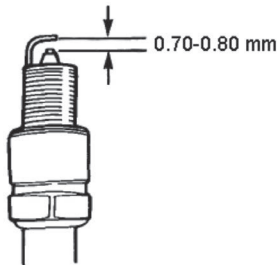
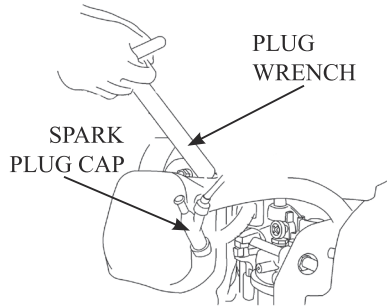

#### NOTICE

Please use the spark plug in a suitable heat range.

## 9. STORAGE

### **⚠ WARNING**

**In order to avoid burning or fire due to contact with any hot part of the generator, don't pack and store the generator before it is cooled.**

If it need be stored for a long time, be sure the storage area is clean and dry.

- (1) Drain the fuel in the fuel tank out, clean strainer, o-ring and sediment, then refit them well. Drain fuel out of the carburetor by loosening the drain bolt, then refit it and screw the carburetor bolt tight.

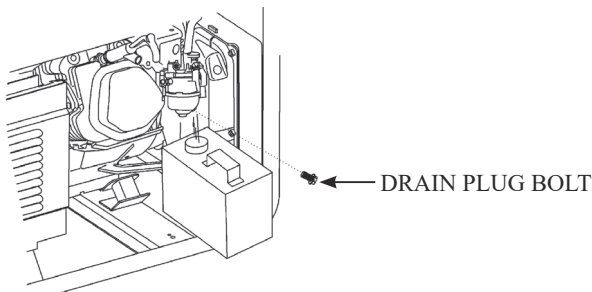

### **⚠ WARNING**

**Gasoline is extremely flammable and is explosive under certain conditions. Drain fuel in a well ventilated area with the engine stopped. Never smoke or allow flames or sparks in the area during this procedure.**

- (2) Screw the oil dipstick off and screw the drain bolt off the crankcase to completely drain the oil out. Then screw back the drain bolt and add fresh oil to upper mark, finally refit the oil dipstick well.

- (3) Remove the spark plug, and pour about a tablespoon of clean engine oil into the cylinder. Crank the engine several revolutions to distribute the oil, then reinstall the spark plug.
- (4) Slowly pull the starter grip until resistance is felt. Let the intake and exhaust valves in “close” position.
- (5) Place the generator in a clean area.

## 10. TROUBLESHOOTING

Engine not to start:

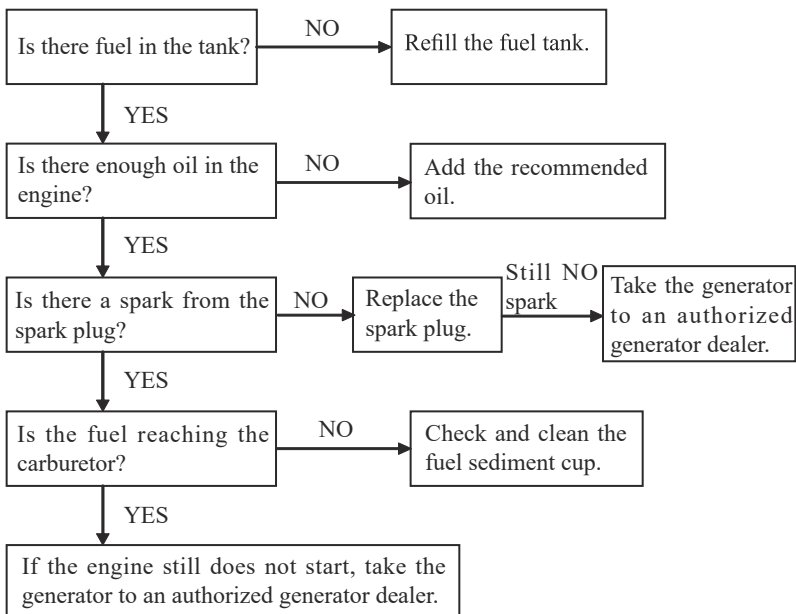

No power supply:

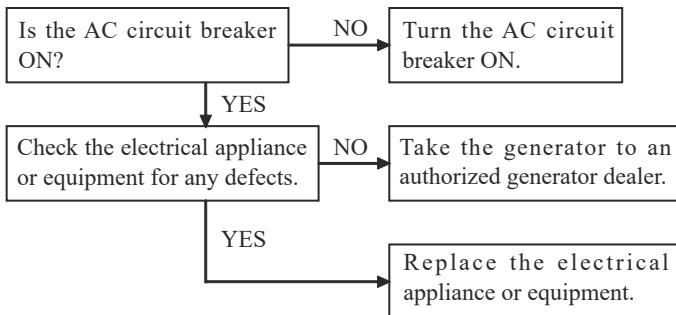



# 11. SPECIFICATIONS

	Item	2.0kW Recoil/ Electric Starter	2.5kW Recoil/ Electric Starter	2.7kW Recoil/ Electric Starter	5.0kWW Recoil/ Electric Starter
Gasoline Engine	Gasoline Engine Style	H210			H420
	Gasoline Engine Type	Air-cooled,4-storke,OHV,single cylinder			
	Displacement (ml)	212			420
	Igniting System	Transistorized Magneto			
	Fuel Volume (L)	18			28
	Fuel Consumption(g/kW·h)	≤395			≤395
	Continuing Time (hr)	8			7
	Oil Capacity (L)	0.55			1.1
Generator	Charging Voltage (DC) (V)	12			
	Charging Current (DC) (A)	8.3			
	Rated Frequency (Hz)	50			
	Rated Voltage (V)	220,230,240			
	Rated Output Power (kW)	2.0	2.5	2.7	5.0
	Maximum Output Power (kW)	2.2	2.8	3.0	5.5
Generator Set	Length (mm)	600			740
	Width (mm)	471			576
	Height (mm)	492			577
	Phase	Single			
General- Purpose Accessory	Large Air Cleaner	●	●	●	●
	Large Muffler	●	●	●	●
	Large Fuel Tank	●	●	●	●
	Fuel Gauge	●	●	●	●
	Voltmeter	●	●	●	●
	Automatic Voltage Regulator(AVR)	●	●	●	●
	Oil Alert System	●	●	●	●
	Non-fuse Breaker	●	●	●	●
	Electric Starting Accessory	●	●	●	●

Remarks: ●means available, - means unavailable

SPECIFICATIONS

	Item	5.5kW Recoil/ Electric Starter	7.0kW Recoil/ Electric Starter	8.0kW Recoil/ Electric Starter
Gasoline Engine	Gasoline Engine Style	H420	H500-V	
	Gasoline Engine Type	Air-cooled,4-storke,OHV,single cylinder		
	Displacement (ml)	420	500	
	Igniting System	Transistorized Magneto		
	Fuel Volume (L)	28	28	
	Fuel Consumption(g/(kW·h))	≤395	≤395	
	Continuing Time (hr)	7	6	
	Oil Capacity (L)	1.1	1.2	
Generator	Charging Voltage (DC) (V)	12		
	Charging Current (DC) (A)	8.3		
	Rated Frequency (Hz)	50		
	Rated Voltage (V)	220,230,240,110/220,115/230		
	Rated Output Power (kW)	5.5	7.0	8.0
	Maximum Output Power (kW)	6.0	7.5	8.5
Generator Set	Length (mm)	740		
	Width (mm)	576		
	Height (mm)	577		
	Phase	Single		
General- Purpose Accessory	Large Air Cleaner	●	●	●
	Large Muffler	●	●	●
	Large Fuel Tank	●	●	●
	Fuel Gauge	●	●	●
	Voltmeter	●	●	●
	Automatic Voltage Regulator(AVR)	●	●	●
	Oil Alert System	●	●	●
	Non-fuse Breaker	●	●	●
	Electric Starting Accessory	●	●	●

Remarks: ●means available, - means unavailable

## 12. WHEEL (OPTION)

Put two wheel shafts through two wheels and gasket separately and then install them on the frame, and fix them with split pin.

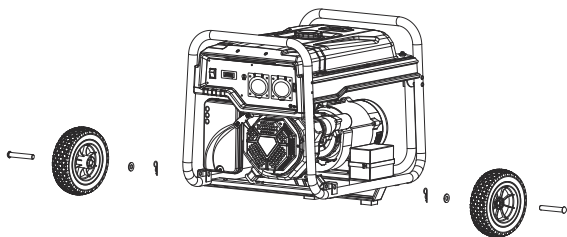

**HYUNDAI**  
POWER PRODUCTS

**For Inquiries, Please Contact:**

Name of Company : C & R Industries

Address : 45 Piet Retief Road, Durban, 4093, South Africa

Tel No. : + 27 (0) 31 463 1433

E-mail : [info@powerproducts.co.za](mailto:info@powerproducts.co.za)

Website/SNS : [www.powerproducts.co.za](http://www.powerproducts.co.za)